

# ASSEMBLY AND INSTALLATION INSTRUCTIONS

T0210

**WARNING:** TO AVOID RISK OF ELECTRICAL SHOCK, BE SURE TO SHUT OFF POWER BEFORE INSTALLING OR SERVICING THIS FIXTURE.

**NOTES:** 1. Before installing, consult local electrical codes for wiring and grounding requirements.  
2. READ AND SAVE THESE INSTRUCTIONS.

## Hardware Package (included):

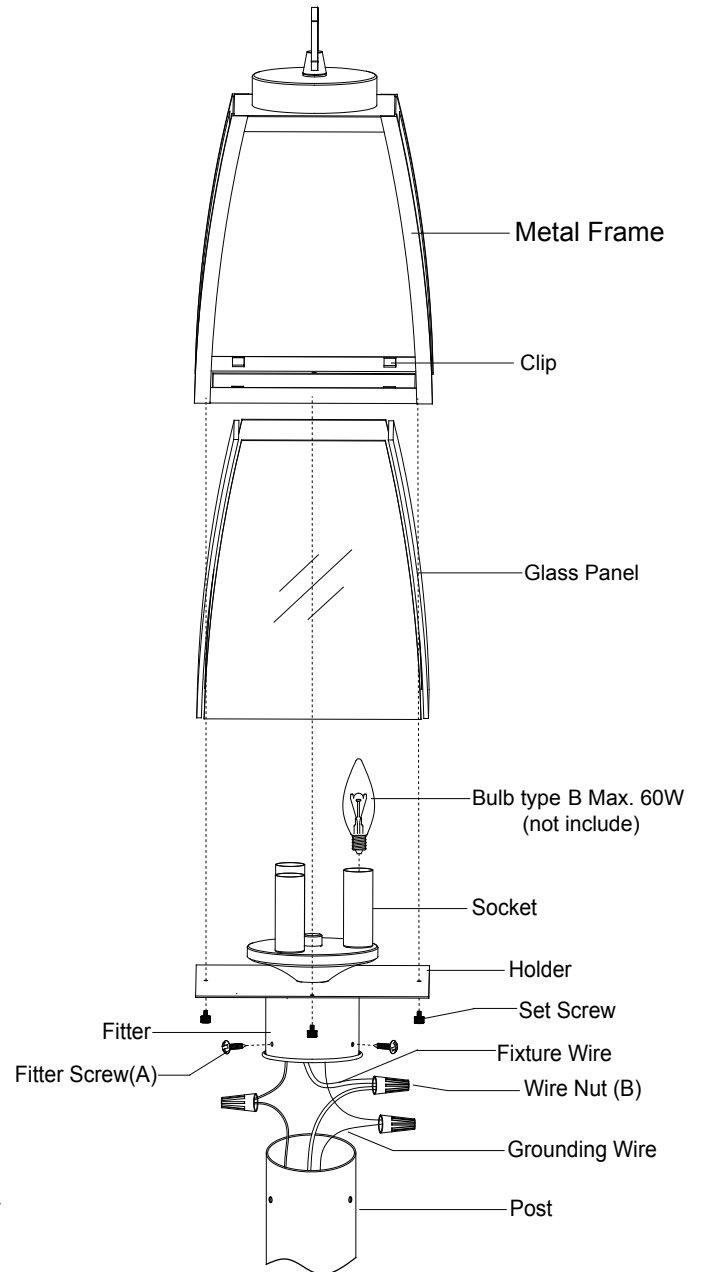
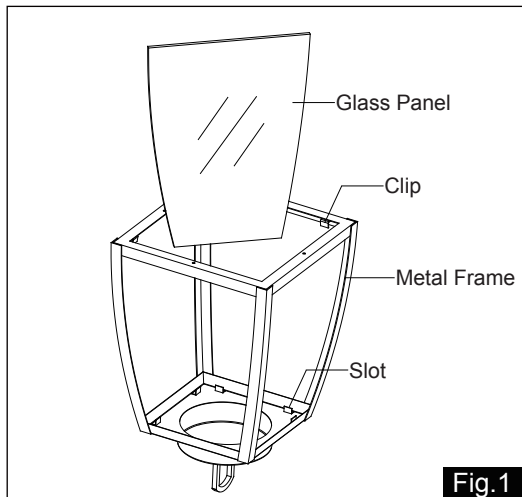
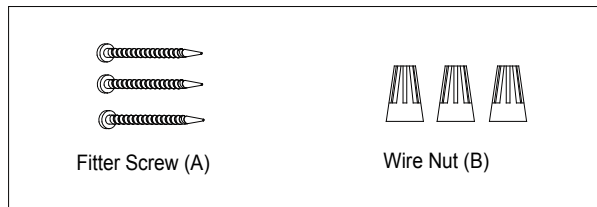

## Installation Steps

Turn off the power at fuse or circuit box.

1. Take a glass panel, tilt and insert it into the slots at one side of the metal frame carefully, secure it by pressing the clips. Repeat with the other glass panels. (See Fig. 1)
2. Install bulbs (not included). Check relamping label at socket area or packaging for maximum allowed wattage.
3. Attach the metal frame to the holder and secure it with four set screws.
3. Pull out the source wires from the post. Make wire connections using wire nuts as follow:
  - Connect the hot wire (usually black insulation) from the fixture to the black wire from the post
  - Connect the neutral wire (usually white insulation) from the fixture to the white wire from the post
  - Attach the fixture grounding wire (usually green insulation or bare wire) to the grounding wire from the post.
 Carefully put the wires back into the post.
4. Place the fitter on the post, then secure it with the fitter screws.

Turn on the power at fuse or circuit box

The following parts are available for re-order if damaged or missing.

**Spare Parts List:**

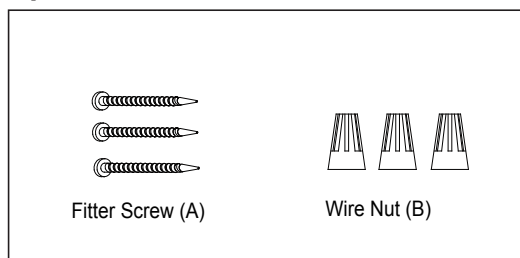

Assembly Kit  
5481MM (1 SET)



Set Screw  
5484BB(4PCS)

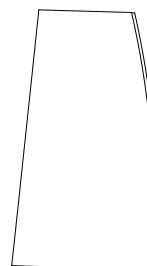

Glass Panel  
9790C(4PCS)

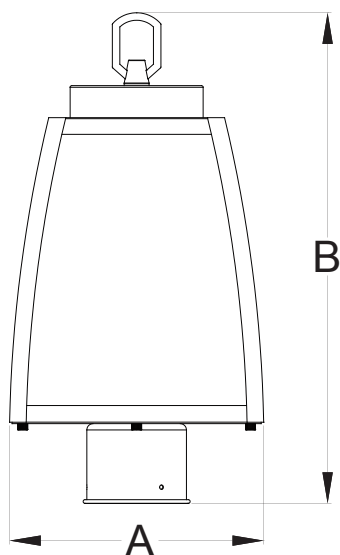

A: 8"

B: 15-1/2"